



# MAXIMATIC® REGULATORS

Maximatic® Regulators provide precise air regulation from 7 to 125 psig. The adjustment knob must be pulled out to adjust the pressure, preventing accidental adjustment. Maximum inlet pressure is 150 psig. Includes bracket and gauge.

**Regulating Range:** 7 to 100 psig standard on MMR-1N, and 7 to 125 psig on all others. 30 and 60 psig ranges also available, add "-P30" or "-P60" to the end of the Part Number.



Dim.	MMR-4Z					
	MMR-1	MMR-2	MMR-3	MMR-4W	MMR-4A	MMR-5
H	2.42 (61.5)	3.74 (95.0)	4.80 (121.8)	5.89 (149.6)	6.06 (153.9)	6.61 (168.0)
HS	0.43 (10.9)	0.67 (17.0)	1.38 (35.0)	1.48 (37.6)	1.59 (40.4)	1.89 (47.3)
HC	1.12 (28.4)	1.86 (47.2)	2.26 (57.4)	2.78 (70.6)	2.78 (70.6)	2.83 (71.9)
HN	0.75 (19.1)	1.00 (25.4)	1.30 (33.0)	1.44 (36.6)	1.44 (36.6)	1.87 (47.5)
HI	0.43 (10.9)	0.65 (16.5)	1.34 (34.0)	1.43 (36.3)	1.43 (36.3)	1.70 (43.2)
TF	0.98 (24.9)	1.57 (39.9)	2.09 (53.1)	2.76 (70.1)	2.76 (70.1)	3.54 (89.9)
TS	1.10 (27.4)	1.34 (34.0)	1.57 (39.9)	2.13 (54.1)	2.13 (54.1)	2.13 (54.1)

Part No.	Port	Gauge Port	Flow Rate	Gauge	
MMR-1N	#10-32	1/16" NPT	4 scfm	100 l/min	PG-10-160J
MMR-2P	1/8" NPT	1/8" NPT	19 scfm	550 l/min	PG-15-160P
MMR-2Q	1/4" NPT	1/8" NPT	19 scfm	550 l/min	PG-15-160P
MMR-3Q	1/4" NPT	1/8" NPT	88 scfm	2,500 l/min	PG-15-160P
MMR-3W	3/8" NPT	1/8" NPT	88 scfm	2,500 l/min	PG-15-160P
MMR-4W	3/8" NPT	1/4" NPT	140 scfm	4,000 l/min	PG-20-160Q
MMR-4Z	1/2" NPT	1/4" NPT	140 scfm	4,000 l/min	PG-20-160Q
MMR-4A	3/4" NPT	1/4" NPT	210 scfm	6,000 l/min	PG-20-160Q
MMR-5B	1" NPT	1/4" NPT	280 scfm	8,000 l/min	PG-20-160Q

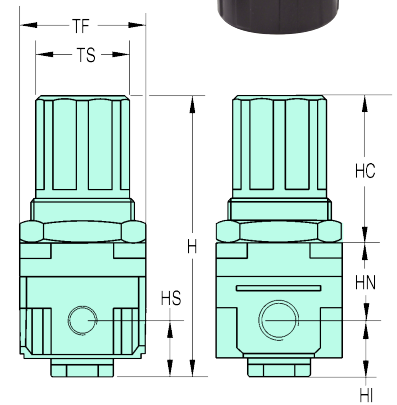

## RELIEVING SHUT-OFF/LOCK OUT VALVES

Maximatic Shut-Off/Lock Out valves may be used in conjunction with Maximatic FRLs to provide a method of turning off the air supply. Cleaning or replacing filters, adding oil to the lubricator or other maintenance steps can be made without the air supply present. The valve can also be locked in the "off" position (lock not provided) to prevent accidental pressurizing.

**Medium:** Air

**Air Flow:** See table below

**Material:** Die Cast Aluminum

**Input Pressure:** 150 psig

**Mounting:** In-line

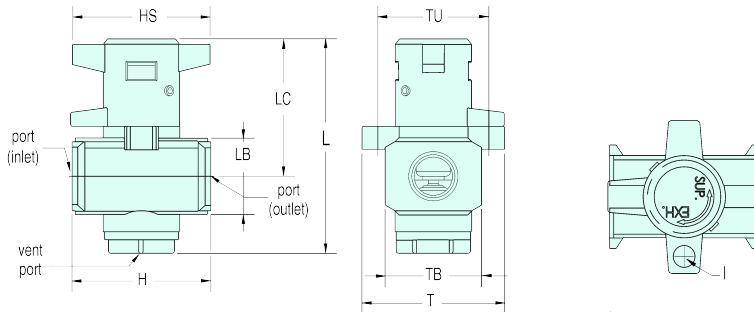

Dim.	MMSV-3QP	MMSV-3WQ	MMSV-3ZW
	MMSV-3PP	MMSV-3QQ	MMSV-3WW
L	2.44 (62.0)	3.07 (78.0)	3.32 (84.3)
H	1.58 (40.1)	2.09 (53.1)	2.76 (70.1)
TB	1.10 (27.9)	1.18 (30.0)	1.42 (36.1)
T	1.62 (41.1)	2.10 (53.3)	2.10 (53.3)
TU	1.26 (32.0)	1.63 (41.4)	1.63 (41.4)
LC	1.57 (39.9)	1.95 (49.5)	2.08 (52.8)
LB	0.87 (22.1)	1.10 (27.9)	1.42 (36.1)
HS	1.58 (40.1)	1.77 (45.0)	1.77 (45.0)
I	0.24 (10.2)	0.29 (7.4)	0.29 (7.4)

Part No.	Port	Vent Port	Air Flow (cfm) @ 100 psig	For Use with FRL, Filter-Regulator, Filter & Regulator Series:					
				MMFRL-2	MMFRLS-2	MMFR-2	MMFRS-2	MMF-2	MMR-2
MMSV-3PP	1/8" NPT	1/8" NPT	18	MMFRL-2	MMFRLS-2	MMFR-2	MMFRS-2	MMF-2	MMR-2
MMSV-3QP	1/4" NPT	1/8" NPT	25	MMFRL-2	MMFRLS-2	MMFR-2	MMFRS-2	MMF-2	MMR-2
MMSV-3QQ	1/4" NPT	1/4" NPT	60	MMFRL-3	MMFRLS-3	MMFR-3	MMFRS-3	MMF-3	MMR-3
MMSV-3WQ	3/8" NPT	1/4" NPT	90	MMFRL-3	MMFRLS-3	MMFR-3	MMFRS-3	MMF-3	MMR-3
MMSV-3WW	3/8" NPT	3/8" NPT	120	MMFRL-4	MMFRLS-4	MMFR-4	MMFRS-4	MMF-4	MMR-4
MMSV-3ZW	1/2" NPT	3/8" NPT	180	MMFRL-4	MMFRLS-4	MMFR-4	MMFRS-4	MMF-4	MMR-4